

* The hardware introduced for the furring strips construction method on this website conform to the ventilation installation method.

Outer wall ventilation installation method

Outer wall ventilation installation method is an excellent installation method that smoothly exhausts moisture to the outside and prevents condensation inside the wall.

Also by keeping the air pressure of the ventilation layer and the outside air at the same level, the intrusion of rainwater into the entire wall is minimized during a storm.

If you could not use the outer wall ventilation installation method...

When the water vapor-rich air in the room flows out through the wall, part of the water vapor is contained in the wall.

The moisture is generated when air containing water vapor condenses due to the temperature difference between indoors and outdoors.

This moisture wets the highly absorbent heat insulating material and deteriorates the heat insulating performance.

When the amount of condensed water increases, the water moves along the heat insulating material, and getting wet structures such as pillars and interior materials, which cause the house to decay.

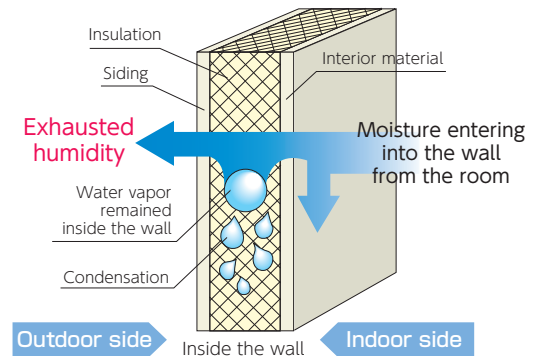

Features in outer wall ventilation installation method

- ① It can prevent internal condensation.
- ② By keeping the air pressure of the ventilation layer and the outside air at the same level, the intrusion of rainwater into the entire wall is minimized during a storm.
- ③ Since the heat insulating material inside the wall is always kept dry, a sufficient heat insulating effect can be obtained.
- ④ Condensation is less likely to occur due to the moisture permeability effect, and it is possible to improve the durability of the building frame.
- ⑤ During midsummer insulation, the air flow in the ventilation layer can suppress the rise in humidity of the entire wall.

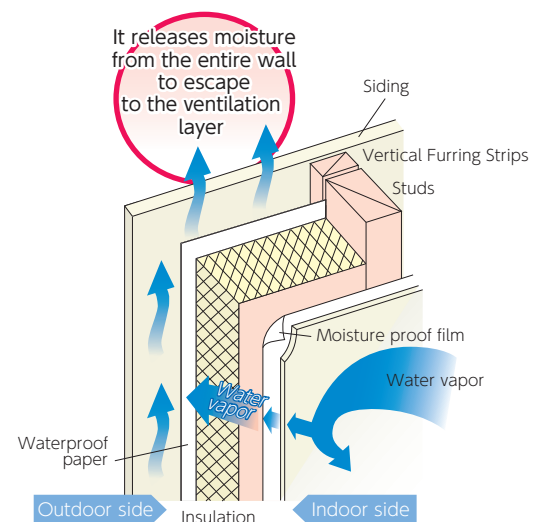

Ventilation layer

The thickness of the ventilation layer should be 12mm or more.

However, if it is predicted that the heat insulating material will protrude (such as behind the framework), set it to 15mm or more.

Ventilation installation method consists of an intake port for taking in outside air, a ventilation layer for passing air, and an exhaust port for discharging the air.

Depending on the shape of the building, there is a way to take it as shown in the figure on the right.

◆Eaves ventilation

An air intake is provided at the base or the connection between the lower house and the wall, and a ventilation layer is provided inside the wall to exhaust air from the eaves soffit.

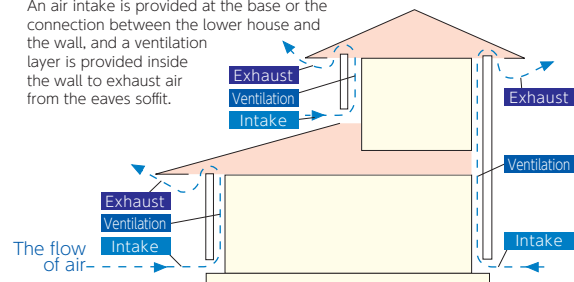

* The hardware introduced for the furring strips construction method on this website conform to the ventilation installation method.

Installation of waterproof paper

Be sure to use official equivalent quality waterproof paper to ensure that moisture is drained.

Base part

Be sure to leave 15mm between the base flashing and the siding for the discharge of condensed water and the intake in the ventilation groove method.

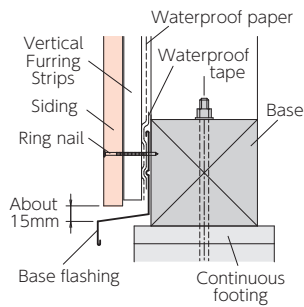

Substrate for horizontal siding (Vertical Furring Strips)

Make a gap of about 30mm between the Vertical Furring Strips and the Furring Strips around the opening part to allow ventilation. In the siding allocation width is 100mm or less at the top and bottom of the opening part, attach a reinforcing Furring Strips.

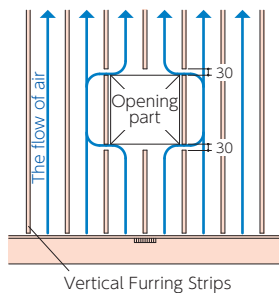

Joint

Joints with other materials should be fitted so that they do not interfere with ventilation.

Eaves, lower roof part

Leave 10mm between the eaves, the lower roof.

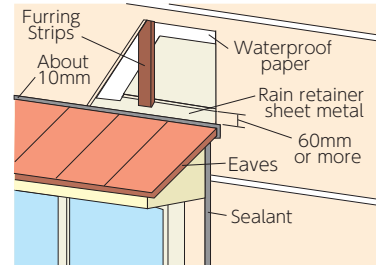

Substrate for vertical siding (Horizontal Furring Strips)

Around the pillars and opening part, leave a gap of about 30mm on the Horizontal Furring Strips to allow ventilation. If the siding allocation width on the left and right of the opening part is 100mm or less, attach a Reinforcing Furring Strips.

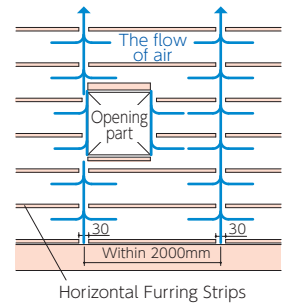

Eaves ceiling

Make sure that the ceiling of the eaves does not block ventilation.

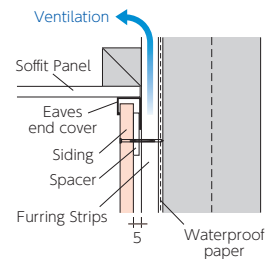

Headboard

Headboard is installed so that the outer wall can be ventilated. The figure 1 below shows the case of ventilation through the metal fittings for headboard. When blocking the bottom of headboard with siding, please carry out so as shown in figure 3 so as not to obstruct the ventilation.

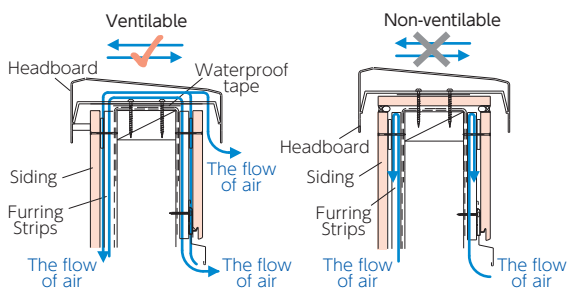

Figure 1
When ventilating through the metal fittings for headboard

Figure 2
When under of headboard is blocked with siding and non-ventilation

Figure 3
When under of headboard is blocked with siding and ventilable

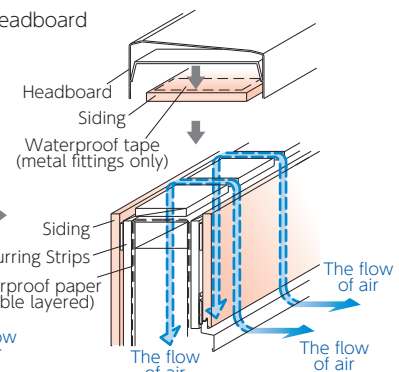

Figure 4
Details of Figure 3